

NOTES:

- 1 ALLOW PLUS TOLERANCE FOR CLEARANCE PER ANSI A115.2.
- 2 LOCK & LATCH CASE SUPPORT BY DOOR MANUFACTURER.
- 3 PLASTER GUARD BY DOOR MANUFACTURER.
- 4 FOR WOOD: $\frac{1}{8}$ " [4] PILOT HOLE IN TWO PLACES.
FOR METAL: DRILL & TAP FOR #8-32 FHMS [M4] IN TWO PLACES.

5 $2\frac{3}{8}$ " [60], $2\frac{3}{4}$ " [70], $3\frac{3}{4}$ " [95], 5" [127]

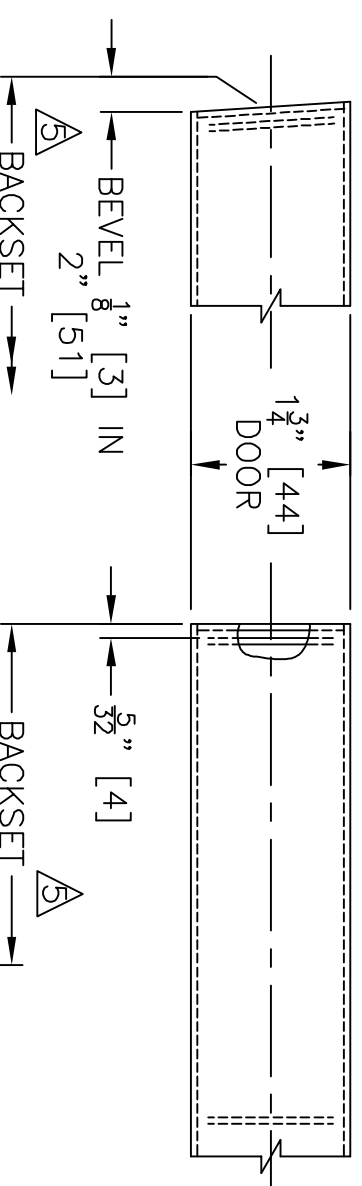
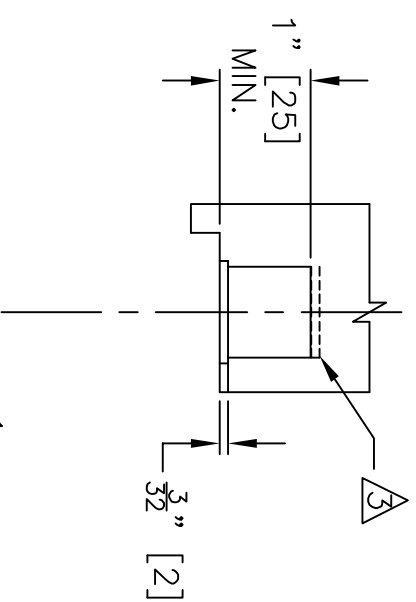

BEVEL EDGE DOOR

UNIVERSAL OR
SQUARE EDGE DOOR

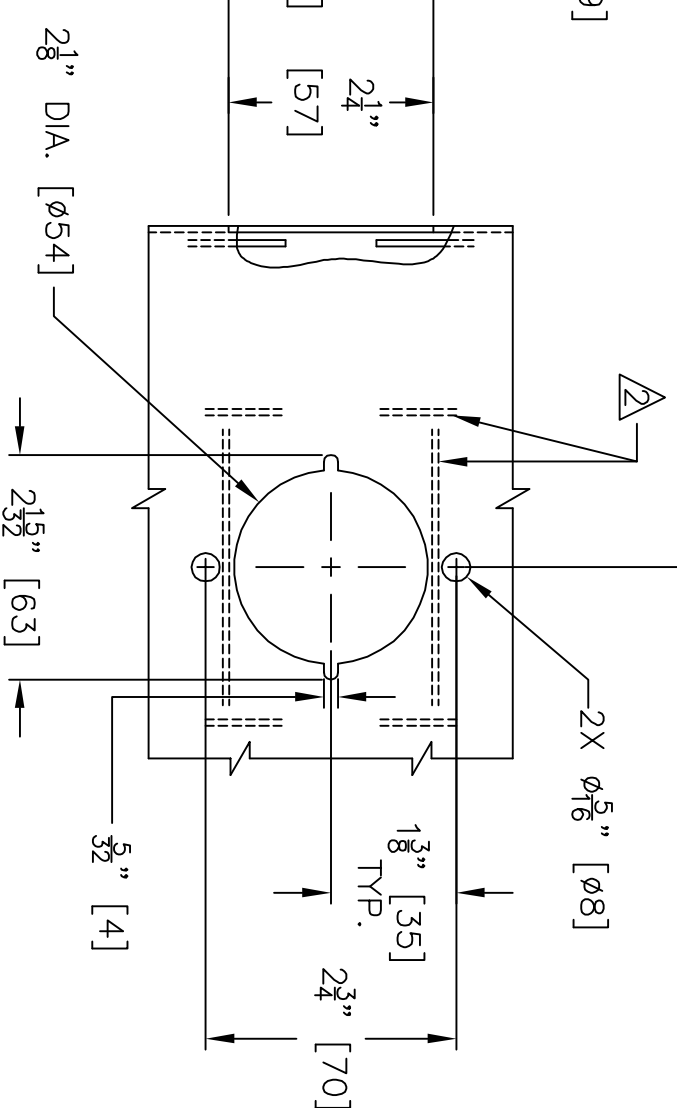
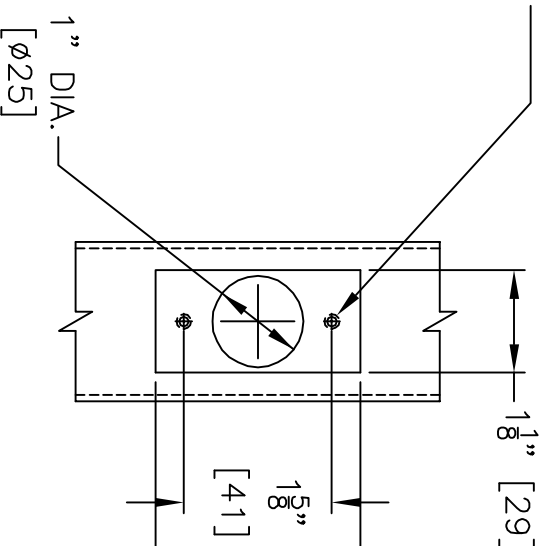
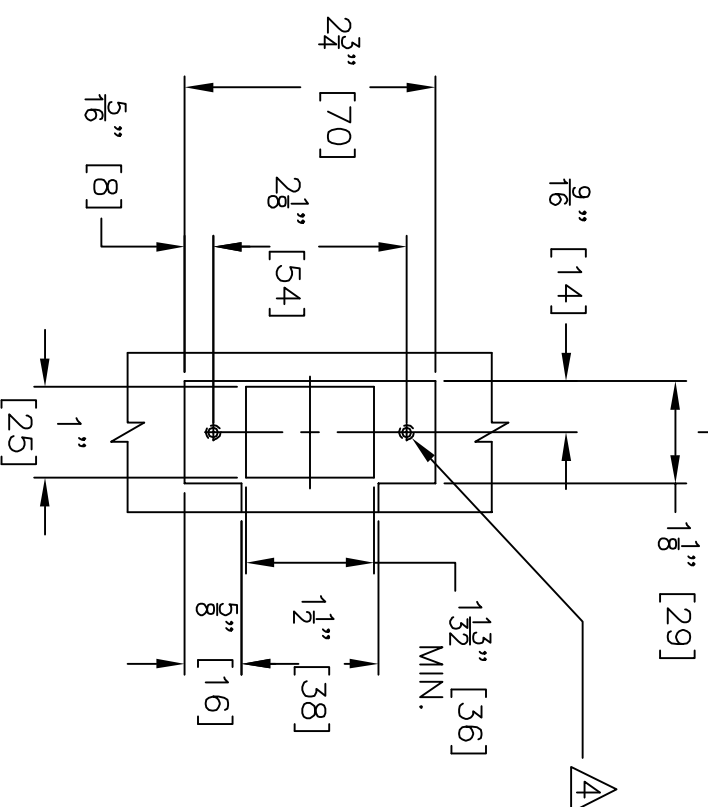

FRAME PREPARATION

DOOR PREPARATION



MARSHALL BEST SECURITY

DOOR & FRAME PREPARATION FOR MB1A AND MB2A CYLINDRICAL LOCKS
SMALL ANSI STRIKE (S2), 1- $\frac{3}{4}$ " DOOR THICKNESS

TEMPLATE MB1AMB2A-S2
JULY 2009